



TECNOLOGIA

DI MONTAGGIO

E DI PARCHEGGIO

DELLE PARTETI

ESEMPI DELL'ARRANGIAMENTO DELLO SPAZIO E DELLA DISPOSIZIONE DELLE ZONE DI PARCHEGGIO

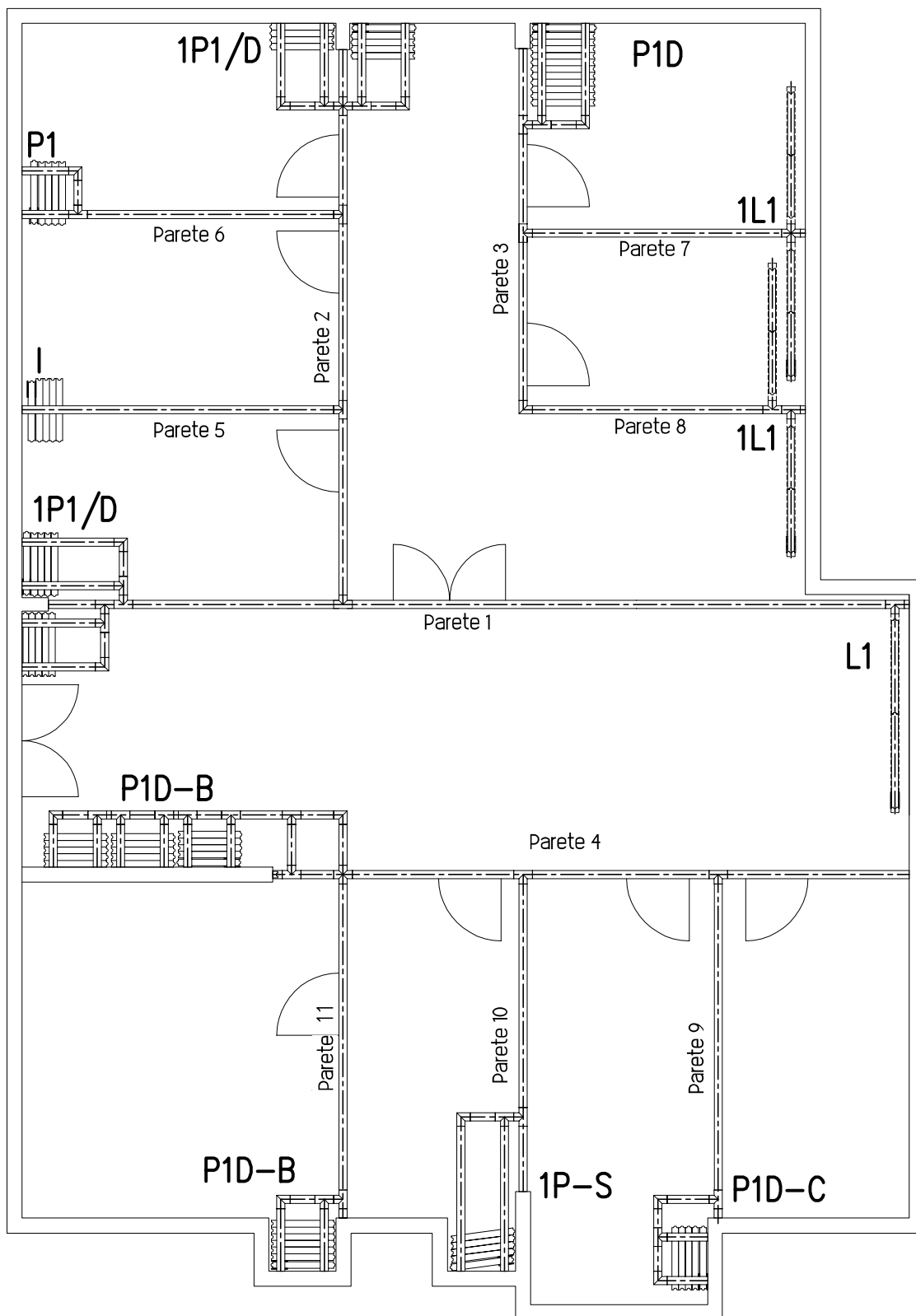

SCHEMI DI PARCHEGGIO

SCHEMI 1

Sistema di parcheggio -J-

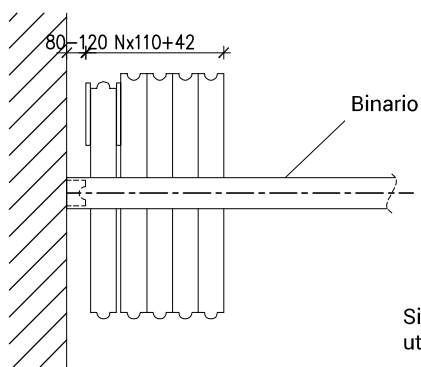

Sistema di parcheggio tipo J (parcheggio nell'asse) utilizzato per moduli a carrello singolo.

SCHEMI NPN

Sistema di parcheggio -P1-

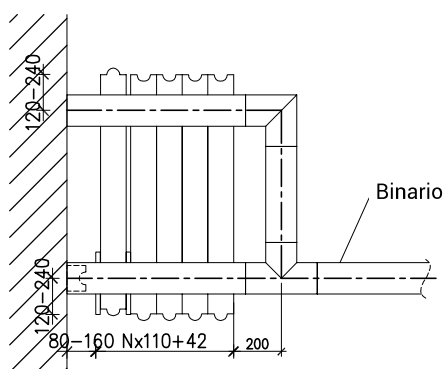

Sistema di parcheggio -P1D-

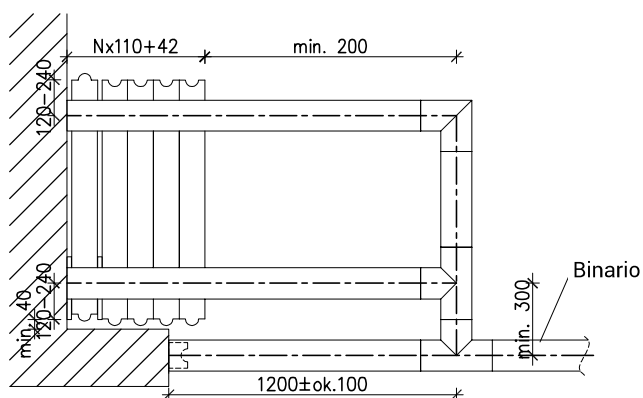

OPTIMAL
SISTEMA DI PARETI MANOVRAILI

SCHEMI DI PARCHEGGIO

Sistema di parcheggio -P1D(B)-

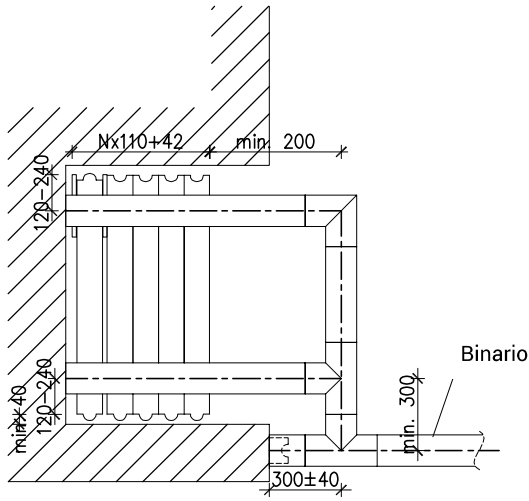

Sistema di parcheggio -1P1/D-

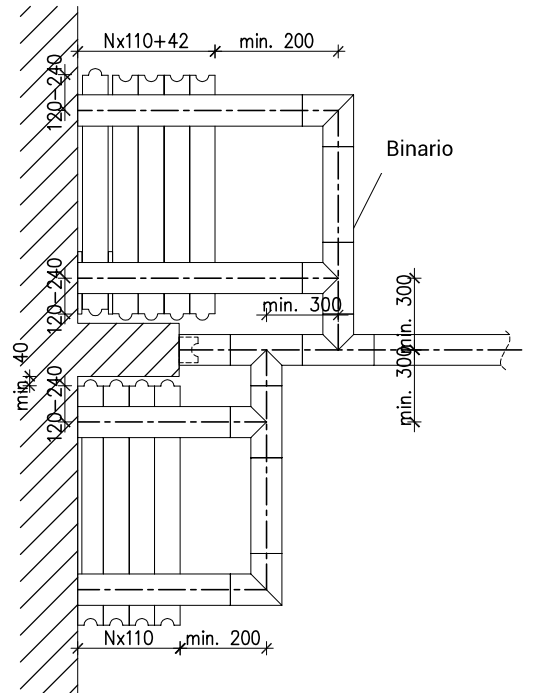

Sistema di parcheggio -P1D(C)-

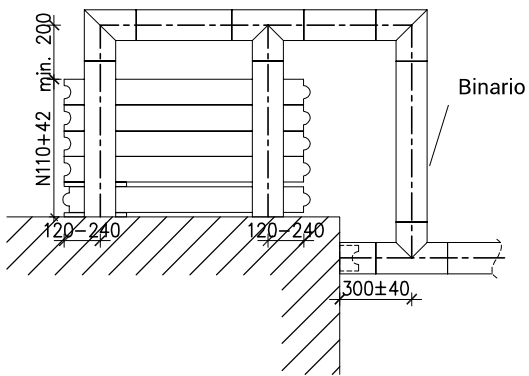

Sistema di parcheggio -1PS-

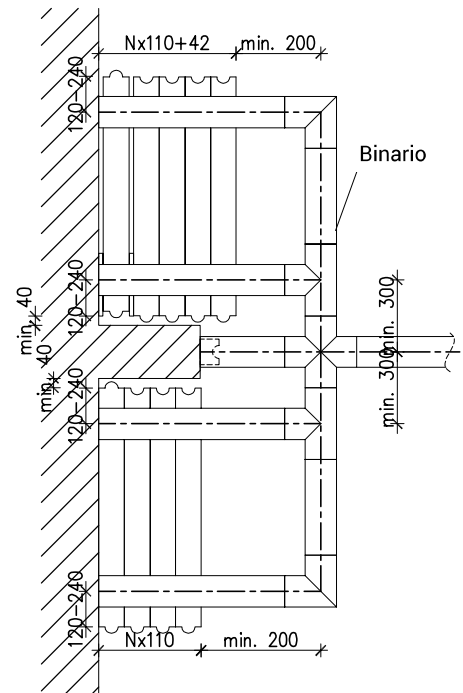
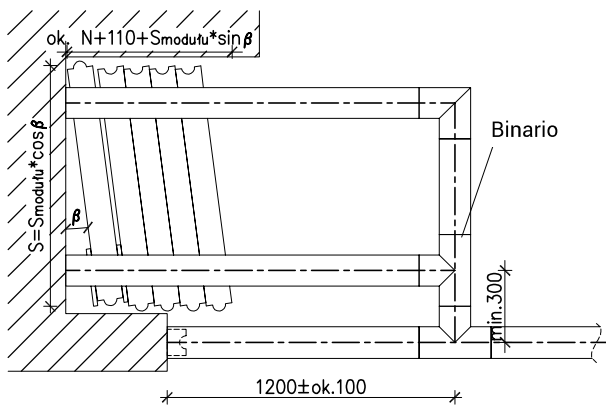

SCHEMI DI PARCHEGGIO

Sistema di parcheggio -L1-

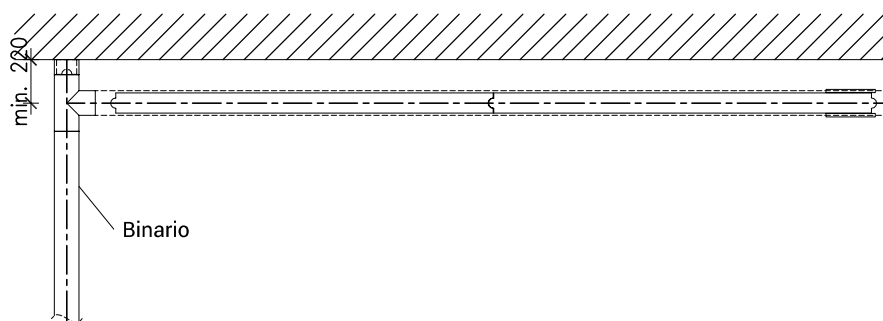

Sistema di parcheggio -1L1-

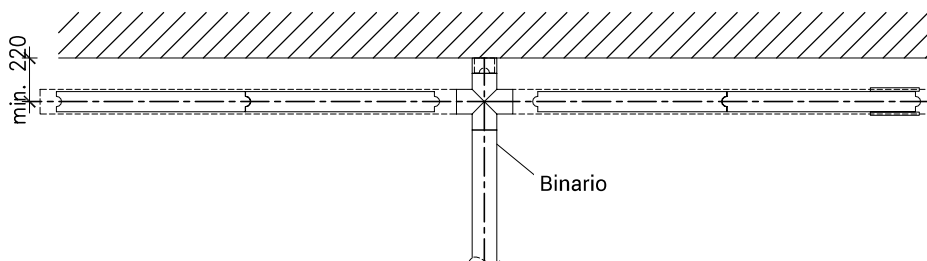

Sistema di parcheggio -1L1- con l'impiego del binario leggero

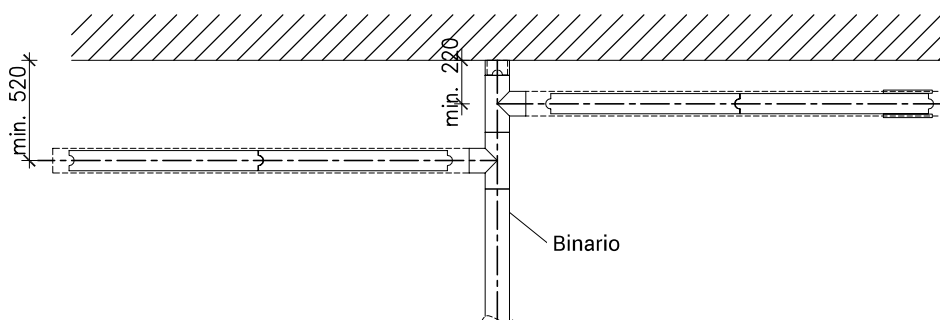

SCHEMI DI PARCHEGGIO

Sistema di parcheggio multiplo

